



 **Infinity**<sup>®</sup>

kappa series  
50.3cs, 60.3cs,  
65.3cs  
instructions

**Thank you** for purchasing Infinity's Kappa Series automotive loudspeaker components. We've organized this manual to make your installation as simple and trouble-free as possible. Please read it thoroughly before proceeding. Remember to keep your sales receipt with this manual in a safe place so both are available for future reference.

## INSTALLATION WARNINGS AND TIPS

### ABOUT THESE INSTRUCTIONS

Installation of automotive stereo components can require extensive experience with a variety of mechanical and electrical procedures. Although these instructions explain how to install Kappa Series Component Systems in a general sense, they do not show the exact installation methods for your particular vehicle. If you do not feel you have the experience, do not attempt the installation yourself, but instead ask your authorized Infinity car audio dealer about professional installation options.

### LOUD MUSIC AND HEARING

Playing loud music in an automobile can hinder your ability to hear traffic, as well as permanently damage your hearing. The maximum volume levels achievable with Infinity speakers, combined with high power amplification, may exceed safe levels for extended listening. We recommend using low volume levels when driving. Infinity accepts no liability for hearing loss, bodily injury, or property damage as a result of use or misuse of this product.

### REAR DECK PRECAUTION

In some cars, fuel tanks may be located directly beneath the rear deck. Before installation, make sure there is adequate speaker basket clearance before considering this location!

### ABOUT THE CONTENTS

The Kappa Component System includes:

- 5-1/4" or 6-1/2" or 165mm woofer
- Grille and mounting adapter(s)
- 1" tweeter with surface/flush I-Mount™ (patent no. 5,859,917) kits
- Crossover network with mounting screws

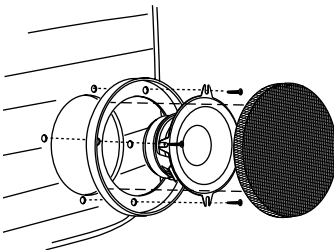
*NOTE: The supplied crossover network is designed to work with the above-listed transducers. Do not substitute another crossover network or use other speakers when connecting the system (see Figure 7A).*

### INSTALLATION TIPS

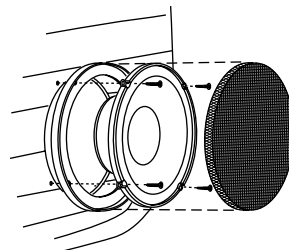
- Always wear protective eyewear when using any tools.
- Turn off all audio components and other electrical devices before you start. Disconnect the (-) negative lead from your vehicle's battery.
- Keep speakers in their package until final installation. When moving a speaker, always rest it with the cone or dome facing up. Never use force to install any speaker.
- Check clearances on both sides of a planned mounting surface before drilling any holes or installing any screws. Remember that the screws can extend behind the surface.
- At the installation sites, locate and make a note of all fuel lines, hydraulic brake lines, vacuum lines and electrical wiring. Use extreme caution when cutting or drilling in and around these areas.
- Before drilling or cutting holes, use a utility knife to remove unwanted fabric or vinyl, to keep material from snagging in a drill bit or saw.
- For door installations, check the clearance with the windows throughout the range of the window's travel, and verify that a mounted speaker will not interfere with the window crank or power window mechanism.
- If mounting speakers elsewhere, check for clearance around rear deck torsion bars, glove box or other structural elements.
- Do not mount speakers where they will get wet.
- If possible, select a mounting site for the crossover network that is near the speakers and provides easy access for connections.

## INSTALLATION

**Figure 1.** Mounting the 50.3cs woofer with the grille.

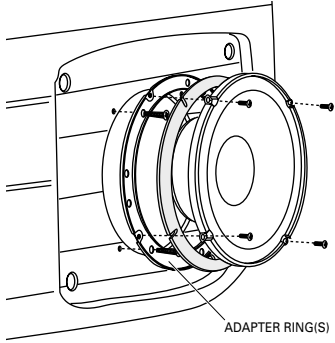


**Figure 2.** Mounting the 60.3cs woofer with the grille.

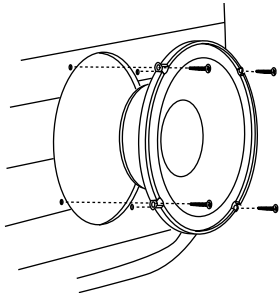


## INSTALLATION

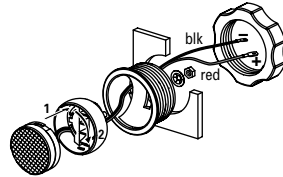
**Figure 3.** Mounting the 60.3cs woofer in a standard speaker location. A variety of adapter rings are supplied to fit many installation configurations.



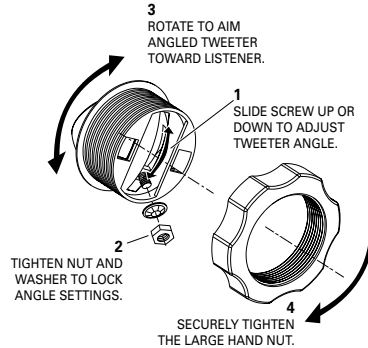
**Figure 4.** Mounting the 65.3cs in a 165mm speaker location.



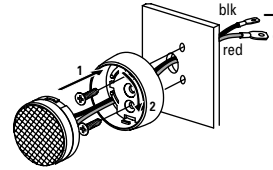
**Figure 5A.** Mounting the tweeter using the I-Mount™ flush-mounting kit.



**Figure 5B.** Aiming the tweeter at a desired listening position.



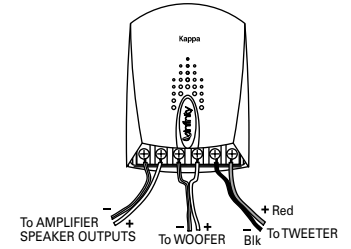
**Figure 6.** Mounting the tweeter using the I-Mount™ surface-mounting kit.



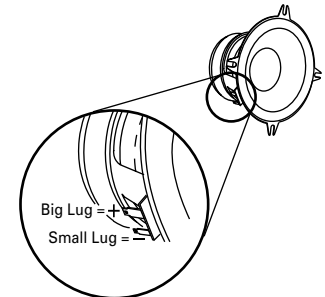
## CONNECTIONS

Remove the cover and mount the crossover network. Observing proper polarity, connect the speakers and amplifier, as shown in Figures 7A and 7B. When done, replace the cover.

**Figure 7A.** Wiring connections on the crossover network (shown with cover on).



**Figure 7B.** Locating wiring connections on the 50.3cs woofer. Other woofers are wired similarly.



## SPECIFICATIONS

### 50.3cs

Type: 5-1/4" 2-Way Component  
Crossover Frequency: 3.5kHz  
Woofers  
Speaker Impedance: 4 ohms  
Power Handling: 85W RMS, 255W Peak  
Sensitivity: 90dB @ 2.83V, 1m  
Frequency Response: 55Hz – 21kHz  
Mounting Depth: 2" (51mm)  
Cut-Out Diameter: 4-5/8" (118mm)  
Tweeter  
Speaker Impedance: 4 ohms  
Power Handling: 50W RMS, 150W Peak  
Sensitivity: 90dB @ 2.83V, 1m  
Frequency Response: 3.5kHz – 21kHz  
Mounting Depth: 1-3/16" (31mm)  
Cut-Out Diameter: 1-7/8" (47mm)

### 60.3cs

Type: 6-1/2" 2-Way Component  
Crossover Frequency: 3.5kHz  
Woofers  
Speaker Impedance: 4 ohms  
Power Handling: 90W RMS, 270W Peak  
Sensitivity: 90dB @ 2.83V, 1m  
Frequency Response: 45Hz – 21kHz  
Mounting Depth: 2-1/16" (53mm)  
Cut-Out Diameter: 5" (127mm)  
Tweeter  
Speaker Impedance: 4 ohms  
Power Handling: 50W RMS, 150W Peak  
Sensitivity: 90dB @ 2.83V, 1m  
Frequency Response: 3.5kHz – 21kHz  
Mounting Depth: 1-3/16" (31mm)  
Cut-Out Diameter: 1-7/8" (47mm)

### 65.3cs

Type: 165mm 2-Way Component  
Crossover Frequency: 3.5kHz  
Woofers  
Speaker Impedance: 4 ohms  
Power Handling: 90W RMS, 270W Peak  
Sensitivity: 90dB @ 2.83V, 1m  
Frequency Response: 45Hz – 21kHz  
Mounting Depth: 2-3/8" (61mm)  
Cut-Out Diameter: 5-1/2" (140mm)  
Tweeter  
Speaker Impedance: 4 ohms  
Power Handling: 50W RMS, 150W Peak  
Sensitivity: 90dB @ 2.83V, 1m  
Frequency Response: 3.5kHz – 21kHz  
Mounting Depth: 1-3/16" (31mm)  
Cut-Out Diameter: 1-7/8" (47mm)



Infinity Systems, Inc., 250 Crossways Park Drive, Woodbury, NY 11797 USA  
(800) 553-3332 • FAX (516) 682-3523 • [www.infinitysystems.com](http://www.infinitysystems.com)  
© 2001 Infinity Systems, Inc. • P/N: KAPCSOM2/01 • Printed 6/01  
H A Harman International Company

### DECLARATION OF CONFORMITY



We, Harman Consumer International  
2, route de Tours  
72500 Chateau-du-Loir  
France

declare in own responsibility, that the products described in this owner's manual are in compliance with technical standards:  
EN 50081-1:1992  
EN 50082-1:1997

Lutz Uphoff  
Harman Consumer International  
Chateau-du-Loir, France 201